

Two Marks Questions and Answers
Solid State Drives
Unit I

1. What is meant by electrical drives?

Systems employed for motion control are called drives and they employ any of the primemovers such as diesel or petrol engines, gas or steam turbines, hydraulic motors and electric motors for supplying mathematical energy for motion control. Drives employing electric motion are called electric drives.

2. Draw the electric drive system.

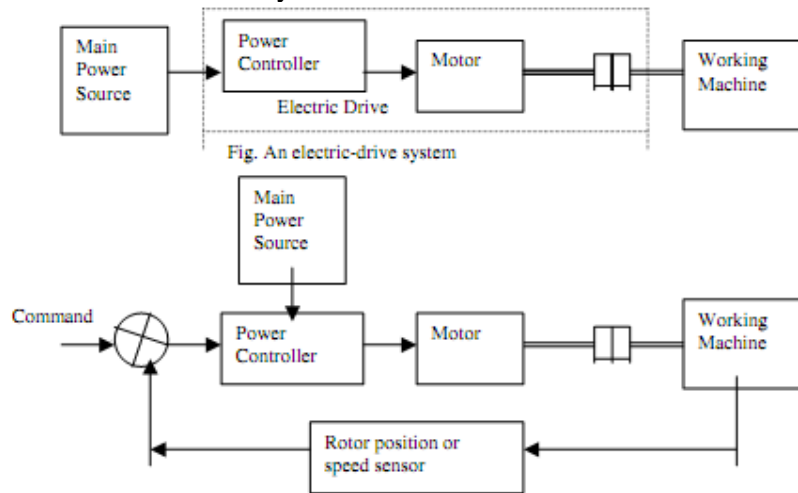

Fig. Modern Electric Drive system using power electronic converter

3. Specify the functions of power modulator.

Power modulator performs one or more of the following four functions.

- a. Modulates flow of power form the source to the motor in such a manner that motor is imparted speed-torque characteristics required by the load.
- b. During transient operations, such as starting, braking and speed reversal, it restricts source and motor currents within permissible values; excessive current drawn from source may overload it or may cause a voltage dip.

4. Mention the different types of drives.

- 1) Group drive
- 2) Individual drive
- 3) Multimotor drive

5. List the different types of electrical drives.

- 1) dc drives
- 2) ac drives

6. What are the advantages of electric drives?

- 1) They have flexible control characteristics. The steady state and dynamic characteristics of electrical drives can be shaped to satisfy load requirements.

2) Drives can be provided with automatic fault detection systems, programmable logic controllers and computers can be employed to automatically ctrl the drive operations in a desired sequence.

3) They are available in which range of torque, speed and power.

4) It can operate in all the four quadrants of speed-torque plane. Electric braking gives smooth deceleration and increases life of the equipment compared to other forms of braking.

5) Control gear required for speed control, starting and braking is usually simple and easy to operate.

7. What are the functions performed by electric drives?

Various functions performed by electric drives include the following.

a. Driving fans, ventilators, compressors and pumps etc.

b. Lifting goods by hoists and cranes

c. Imparting motion to conveyors in factories, mines and warehouses and

d. Running excavators and escalators, electric locomotives, trains, cars, trolley buses, lifts and drums winders etc.

8. What are the disadvantages of electric drives?

The disadvantages of electric drives are

a. Electric drives system is tied only up to the electrified area.

b. The condition arising under the short circuits, leakage from conductors and breakdown of overhead conductor may lead to fatal accidents.

c. Failure in supply for a few minutes may paralyses the whole system.

9. What are the advantages of group drive over individual drive?

The advantages of group drive over individual drive are

a. Initial cost: Initial cost of group drive is less as compared to that of the individual drive.

b. Sequence of operation : Group drive system is useful because all the operations are stopped simultaneously.

c. Space requirement : Less space is required in group drive as compared to individual drive.

d. Low maintenance cost: It requires little maintenance as compared to individual drive.

10. What the group drive is not used extensively.

Although the initial cost of group drive is less but yet this system is not used extensively because of following disadvantages.

a. Power factor: Group drive has low power factor

b. Efficiency : Group drive system when used and if all the machines are not working together the main motor shall work at very much reduced load.

c. Reliability: In group drive if the main motor fails whole industry will come to stand still.

d. Flexibility: Such arrangement is not possible in group drive i.e., this arrangement is not suitable for the place where flexibility is the prime factor.

e. Speed: Group drive does not provide constant speed.

f. Types of machines : Group drive is not suitable for driving heavy machines such as cranes, lifts and hoists etc.

11. Write short notes on individual electric drives.

In individual drive, each individual machine is driven by a separate motor. This motor also imparts motion to various other parts of the machine. Examples of such machines are single spindle drilling machines (Universal motor is used) and lathes. In a lathe, the motor rotates the spindle, moves the feed and also with the help of gears, transmits motion to lubricating and cooling pumps. A three phase squirrel cage induction motor is used as the drive. In many such applications the electric motor forms an integral part of the machine.

12. Mention the different factors for the selection of electric drives?

- 1) Steady state operation requirements.
- 2) Transient operation requirements.
- 3) Requirements related to the source.
- 4) Capital and running cost, maintenance needs, life.
- 5) Space and weight restriction.
- 6) Environment and location.
- 7) Reliability.

13. Mention the parts of electrical drives.

- 1) Electrical motors and load.
- 2) Power modulator
- 3) Sources
- 4) Control unit
- 5) Sensing unit

14. Mention the applications of electrical drives

- Paper mills
- Electric traction
- Cement mills
- Steel mills

15. Mention the types of enclosures

- Screen projected type
- Drip proof type
- Totally enclosed type
- Flame proof type

16. Mention the different types of classes of duty

- Continuous duty
- Discontinuous duty
- Short time duty
- Intermittent duty

17. What is meant by regenerative braking?

Regenerative braking occurs when the motor speed exceeds the synchronous speed. In this case the IM runs as the induction m/c is converting the mechanical power into electrical power which is delivered back to the electrical system. This method of braking is known as regenerative braking.

18. What is meant by dynamic braking?

Dynamic braking of electric motors occurs when the energy stored in the rotating mass is dissipated in an electrical resistance. This requires a motor to operate as a gen. to convert the stored energy into electrical.

19. What is meant by plugging?

It is one method of braking of IM. When phase sequence of supply of the motor running at the speed is reversed by interchanging connections of any two phases of stator with respect to supply terminals, operation shifts from motoring to plugging region.

20. What is critical speed?

It is the speed that separates continuous conduction from discontinuous conduction mode.

21. Which braking is suitable for reversing the motor?

Plugging is suitable for reversing the motor.

22. Define equivalent current method

The motor selected should have a current rating more than or equal to the current. It is also necessary to check the overload of the motor. This method of determining the power rating of the motor is known as equivalent current method.

23. What are the methods of operation of electric drives?

- Steady state
- acceleration including starting
- deceleration including starting

24. Define four quadrant operation.

The motor operates in two mode: motoring and braking. In motoring, it converts electrical energy into mechanical energy which supports its motion. In braking, it works as a generator, converting mathematical energy into electrical energy and thus opposes the motion. Motor can provide motoring and braking operations for both forward and reverse directions.

25. What is meant by mechanical characteristics?

The curve is drawn between speed and torque. This characteristic is called mechanical characteristics.

26. Mention the types of braking

- Regenerative braking
- Dynamic braking
- Plugging

UNIT II

1. What are the advantage and disadvantages of D.C. drives?

The advantages of D.C. drives are,

- a. Adjustable speed
- b. Good speed regulation
- c. Frequent starting, braking and reversing.

The disadvantage of D.C. drives is the presence of a mechanical commutator which limits the maximum power rating and the speed.

2. Give some applications of D.C. drives.

The applications of D.C. drives are,

- a. Rolling mills
- b. Paper mills
- c. Mine winders
- d. Hoists
- e. Machine tools
- f. Traction
- g. Printing presses
- h. Excavators
- i. Textile mills
- j. Cranes.

3. Why the variable speed applications are dominated by D.C. drives?

The variable speed applications are dominated by D.C. drives because of lower cost, reliability and simple control.

4. What is the use of flywheel? Where it is used?

It is used for load equalization. It is mounted on the motor shaft in compound motor.

5. What are the advantages of series motor? The advantages of series motors are,

- a. High starting torque
- b. Heavy torque overloads.

6. How the D.C. motor is affected at the time of starting?

A D.C. motor is started with full supply voltage across its terminals, a very high current will flow, which may damage the motor due to heavy sparking at commutator and heating of the winding. Therefore, it is necessary to limit the current to a safe value during starting.

7. Define and mention different types of braking in a dc motor?

In braking, the motor works as a generator developing a negative torque which opposes the motion. Types are regenerative braking, dynamic or rheostat braking and plugging or reverse voltage braking.

8. List the drawbacks of armature resistance control?

In armature resistance control speed is varied by wasting power in external resistors that are connected in series with the armature. Since it is an inefficient method of speed control it was used in intermittent load applications where the duration of low speed operations forms only a small proportion of total running time.

9. What is static Ward-Leonard drive?

Controlled rectifiers are used to get variable d.c. voltage from an a.c. source of fixed voltage controlled rectifier fed dc drives are also known as static Ward-Leonard drive.

10. What is a line commutated inverter?

Full converter with firing angle delay greater than 90 deg. is called line commutated inverter. Such an operation is used in regenerative braking mode of a dc motor in which case a back emf is greater than applied voltage.

11. Mention the methods of armature voltage controlled dc motor?

When the supplied voltage is ac,

Ward-Leonard schemes

Transformer with taps and un controlled rectifier bridge

Static Ward-Leonard scheme or controlled rectifiers

When the supply is dc:

Chopper control

12. How is the stator winding changed during constant torque and constant horsepower operations?

For constant torque operation, the change of stator winding is made from series – star to parallel – star, while for constant horsepower operation the change is made from series-delta to parallel-star. Regenerative braking takes place during changeover from higher to lower speeds.

13. Define positive and negative motor torque.

Positive motor torque is defined as the torque which produces acceleration or the positive rate of change of speed in forward direction. Positive load torque is negative if it produces deceleration.

14. What are the disadvantages of conventional Ward-Leonard schemes?

- Higher initial cost due to use of two additional m\cs.
- Heavy weight and size.
- Needs more floor space and proper foundation.
- Required frequent maintenance. Higher noise and higher loss.

15. Mention the drawbacks of rectifier fed dc drives?

- Distortion of supply.
- Low power factor.
- Ripple in motor current

16. What are the advantages in operating choppers at high frequency?

The operation at a high frequency improves motor performance by reducing current ripple and eliminating discontinuous conduction.

17. Why self commutated devices are preferred over thyristors for chopper circuits?

Self commutated devices such as power MOSFETs power transistors, IGBTs, GTOs and IGCTs are preferred over thyristors for building choppers because they can be commutated by a slow power control signal and don' t need commutation circuit.

18. State the advantages of dc chopper drives?

Dc chopper device has the advantages of high efficiency, flexibility in control, light weight, small size, quick response and regeneration down to very low speed.

19. What are the advantages of closed loop c of dc drives?

Closed loop control system has the adv. of improved accuracy, fast dynamic response and reduced effects of disturbance and system non-linearities.

20. What are the types of control strategies in dc chopper?

- Time ratio control.
- Current limit control.

21. What is the use of controlled rectifiers?

Controlled rectifiers are used to get variable D.C. Voltage from an A.C. Source of fixed voltage.

22. What is known as half-controlled rectifier and fully controlled rectifier?

The rectifiers that provide control of dc voltage in either direction and therefore, allow motor control in quadrants I and IV. They are known as fully-controlled rectifiers.

The rectifiers that allow dc voltage control only in one direction and motor control in quadrant I only. They are known as half-controlled rectifiers.

23. What is called continuous and discontinuous conduction?

A dc motor is fed from a phase controlled converter the current in the armature may flow in discrete pulses in called continuous conduction.

A dc motor is fed from a phase controlled converter the current in the armature may flow continuously with an average value superimposed on by a ripple is called discontinuous conduction.

24. What are the three intervals present in discontinuous conduction mode of single phase half and fully controlled rectifier?

The three intervals present in half controlled rectifier are,

- a. Duty interval
- b. Free, wheeling interval
- c. Zero current interval.

The two intervals present in fully controlled rectifier are

- a. Duty interval
- b. Zero current interval

25. What is called inversion?

Rectifier takes power from D.C. terminals and transfers it to A.C. mains is called inversion.

26. What are the limitations of series motor? Why series motor is not used in traction applications now a days?

1. The field of series cannot be easily controlled. If field control is not employed, the series motor must be designed with its base speed equal to the highest desired speed of the drive.

2. Further, there are a number of problems with regenerative braking of a series motor. Because of the limitations of series motors, separately excited motors are now preferred even for traction applications.

UNIT III

1. What is a closed loop control system?

A closed loop system is mainly used to maintain constant speed operation. It is a system in which the output has control over the input.

2. What are the advantages of closed loop system?

- a. System protection.
- b. Greater accuracy
- c. Improved dynamic response
- d. Reduced effects of disturbances such as loading.

3. What are the basic blocks of a closed loop system of a dc motor?

The system consists of a dc motor, power converter, feedback path, comparator and speed controller.

4. What are the two types of feedback in dc drive?

- a. Current feedback
- b. Speed feedback

5. What is speed feedback?

The motor speed can be sensed by any one speed sensor and this signal is compared with reference speed. This error signal is given to speed controller. The speed controller produce control signal to the power converter.

6. How is the speed of a motor sensed?

The speed of a motor can be sensed by using a tachogenerator.

7. What are the two types of speed controller?

- Proportional controller
- Proportional Integral controller

8. What is current feedback?

The motor current can be sensed by current transducer. This signal is compared with reference signal. The error signal is fed to the current controller produces a control signal. This signal is fed to the power converter for controlling the output.

9. What is armature voltage control?

The dc motor speed can be varied by varying armature voltage and field voltage is constant. This voltage can be varied by using power converter. This method only applicable for below base speed.

10. What is field weakening control?

The dc motor speed can be varied by varying the field current and armature voltage is kept constant. The field current can be controlled by using power converter. By using this method the motor field flux decreases i.e., field weakening mode. This method is only applicable for speeds above base speed because speed is inversely proportional to flux.

11. What is the purpose of current control in dc drives?

The current control loop is used for the purpose of limiting the transient over current.

12. What happens if the control loop is without current loop?
If inner current loop is not added in the control circuitry, transient over current is produced which is undesirable from the standpoint of converter rating and protection. This is particularly in case of starting or other large changes.
13. What is the advantage of using simulation package?
Simulation packages are used for studying the nature of the system developed without being practically implementing it.
14. What are the main disadvantages of phase controlled converter fed dc motor drives?
The phase controlled rectifiers always consume reactive power. Due to this, they are expensive to operate where the reactive power is to be paid for. It also generates harmonics.
15. What is the advantage of using PI type speed controller?
The addition of an integral feedback can be used to eliminate the steady-state error and to reduce the forward gain required.
16. Which type of converter can be selected if the input is ac?
When the input is ac, the dc motor can be operated from rectifiers. If the motor ratings are low, we can use single phase controlled rectifiers and for high ratings, three phase controlled rectifiers are used.
17. What is the advantage of closed torque control scheme?
It finds application in battery operated vehicles such as electric trains.
18. What is the use of current limiter in the closed loop control system?
It saturates and sets current reference for inner current loop at a value corresponding to the maximum allowable current.
19. What are the advantages of using PI controller in closed loop controller of dc drive?
- Stabilize the drive
 - Adjust the damping ratio at the desired value
 - Makes the steady state speed error close to zero by integral action and filters out noise again due to the integral action.

UNIT IV

1. What are the different methods of braking applied to the induction motor?
- Regenerative braking
 - Plugging
 - Dynamic braking.
2. What are the different methods of speed control of IM?
- Stator voltage control
 - Supply freq. control
 - Rotor resistance control
 - Slip power recovery control.

3. What is meant by stator voltage control?

The speed of the IM can be changed by changing the stator voltage because the torque is proportional to the square of the voltage.

4. Mention the application of stator voltage control.

This method is suitable for applications where torque demand reduced with speed, which points towards its suitability for fan and pump drives.

5. Mention the applications of ac drives.

AC drives are used in a no. of applications such as fans, blowers, mill run-out tables, cranes, conveyors, traction etc.

6. What are the three regions in the speed-torque characteristics in the IM?

- Motoring region ($0 \leq s \leq 1$)
- Generating region ($s < 0$)
- Plugging region ($1 \leq s \leq 2$) where s is the slip.

7. What are the advantages of stator voltage control method?

- The control circuitry is simple
- Compact size
- Quick response time
- There is considerable savings in energy and thus it is economical method as compared to other methods of speed control.

8. What is meant by soft start?

The ac voltage controllers show a stepless control of supply voltage from zero to rated voltage. They are used for soft start for motors.

9. List the advantages of squirrel cage IM?

- Cheaper
- Light in weight
- Rugged in construction
- More efficient
- Require less maintenance
- It can be operated in dirty and explosive environment

10. Define slip.

The difference between the synchronous speed (N_s) and actual speed (N) of the rotor is known as slip speed. the % of slip is given by,

$$\% \text{ slip } s = \frac{(N_s - N)}{N_s} \times 100$$

11. Define base speed.

The synchronous speed corresponding to the rated freq is called the base speed.

12. What is meant by frequency control of IM?

The speed of IM can be controlled by changing the supply freq because the speed is directly proportional to supply frequency. This method of speed ctrl is called freq control.

13. What is meant by V/F control ?

When the frequency is reduced the i/p voltage must be reduced proportionally so as to maintain constant flux otherwise the core will get saturated resulting in excessive iron loss and magnetizing current. This type of IM behaviour is similar to the working of dc series motor.

14. What are the advantages of V/F control?

- Smooth speed ctrl
- Small i/p current and improved power factor at low freq. start
- Higher starting torque for low case resistance

15. What is meant by stator current control?

The 3 phase IM speed can be controlled by stator current control. The stator current can be varied by using current source inverter.

16. What are the 3 modes of region in the adjustable-freq IM drives characteristics?

- Constant torque region Constant power region
- High speed series motoring region

17. What are the two modes of operation in the motor?

The two modes of operation in the motor are, motoring and braking. In motoring, it converts electrical energy to mechanical energy, which supports its motion. In braking, it works as a generator converting mechanical energy to electrical energy and thus opposes the motion.

18. How will you select the motor rating for a specific application?

When operating for a specific application motor rating should be carefully chosen that the insulation temperature never exceed the prescribed limit. Otherwise either it will lead to its immediate thermal breakdown causing short circuit and damage to winding, or it will lead to deterioration of its quality resulting into thermal breakdown in near future.

19. What is braking? Mention its types.

The motor works as a generator developing a negative torque which opposes the motion is called braking. It is of three types. They are,

- a. Regenerative braking.
- b. Dynamic or rheostat braking.
- c. Plugging or reverse voltage braking.

20. What are the three types of speed control?

The three types of speed control as,

- a. Armature voltage control
- b. Field flux control
- c. Armature resistance control.

21. What are the advantages of armature voltage control?

The advantages of armature voltage control are,

- a. High efficiency
- b. Good transient response
- c. Good speed regulation.

22. What are the methods involved in armature voltage control?

When the supply is in A.C.

- a. Ward-Leonard schemes
- b. Transformer with taps and an uncontrolled rectifier bridge.
- c. Static Ward Leonard scheme or controlled rectifiers when the supply is in D.C.
- d. Chopper control.

23. Give some drawbacks and uses of Ward-Leonard drive

The drawbacks of Ward Leonard drive are

- a. High initial cost
- b. Low efficiency

The Ward-Leonard drive is used in rolling mills, mine winders, paper mills, elevators, machine tools etc.

24. Give some advantages of Ward-Leonard drive.

The advantages of Ward-Leonard drive are,

- a. Inherent regenerative braking capability
- b. Power factor improvement.

25. What are the advantages of induction motors over D.C. motors?

The main drawback of D.C. motors is the presence of commutator and brushes, which require frequent maintenance and make them unsuitable for explosive and dirty environments. On the other hand, induction motors, particularly squirrel-cage are rugged, cheaper, lighter, smaller, more efficient, require lower maintenance and can operate in dirty and explosive environments.

26. Give the applications of induction motor drives.

Although variable speed induction motor drives are generally expensive than D.C. drives, they are used in a number of applications such as fans, blowers, mill run-out tables, cranes, conveyors, traction etc., because of the advantages of induction motors. Other applications involved are underground and underwater installations, and explosive and dirty environments.

27. How is the speed controlled in induction motor?

The induction motor speed can be controlled by supplying the stator a variable voltage, variable frequency supply using static frequency converters. Speed control is also possible by feeding the slip power to the supply system using converters in the rotor circuit. Basically one distinguishes two different methods of speed control.

a. Speed control by varying the slip frequency when the stator is fed from a constant voltage, constant frequency mains.

b. Speed control of the motor using a variable frequency variable voltage motor operating at constant rotor frequency.

28. How is the speed control by variation of slip frequency obtained?

Speed control by variation of slip frequency is obtained by the following ways.

- a. Stator voltage control using a three-phase voltage controller.
- b. Rotor resistance control using a chopper controlled resistance in the rotor circuit.
- c. Using a converter cascade in the rotor circuit to recover slip energy.
- d. Using a cyclo converter in the rotor circuit.

29. Mention the effects of variable voltage supply in a cage induction motor.

When a cage induction motor is fed from a variable voltage for speed control the following observations may be made.

- a. The torque curve beyond the maximum torque point has a negative slope. A stable operating point in this region is not possible for constant torque load.
- b. The voltage controlled must be capable of withstanding high starting currents. The range of speed control is rather limited.
- c. The motor power factor is poor.

30. Classify the type of loads driven by the motor.

The type of load driven by the motor influences the current drawn and losses of the motor as the slip varies. The normally occurring loads are

- a. Constant torque loads.
- b. Torque varying proportional to speed.
- c. Torque varying preoperational to the square of the speed.

31. What are the disadvantages of constant torque loads?

The constant torque loads are not favoured due to increase in the losses linearly with slip and becoming maximum at $s = 1.0$. This is obvious from the variation of flux as the voltage is varied for speed control. To maintain constant torque the motor draws heavy current resulting in poor torque/ampere, poor efficiency and poor power factor at low speeds.

32. How is the speed of a squirrel cage induction motor controlled?

The speed of a squirrel cage induction motor can be controlled very effectively by varying the stator frequency. Further the operation of the motor is economical and efficient, if it operates at very small slips. The speed of the motor is therefore, varied by varying the supply frequency and maintaining the rotor frequency at the rated value or a value corresponding to the required torque on the linear portion of the torque-speed curve.

33. Why the control of a three-phase induction motor is more difficult than D.C. motors?

The control of a three-phase induction motor, particularly when the dynamic performance involved is more difficult than D.C. motors. This is due to

- a. Relatively large internal resistance of the converter causes voltage fluctuations following load fluctuations because the capacitor cannot be ideally large.
- b. In a D.C. motor there is a decoupling between the flux producing magnetizing current and torque producing armature current. They can be independently controlled. This is not the case with induction motors.
- c. An induction motor is very poorly damped compared to a D.C. motor.

34. Where is the V/f control used?

The V/f control would be sufficient in some applications requiring variable torque, such as centrifugal pumps, compressors and fans. In these, the torque varies as the square of the speed. Therefore at small speeds the required torque is also small and V/f control would be sufficient to drive these loads with no compensation required for resistance drop. This is true also for the case of the liquid being pumped with minimal solids.

35. What are the components of the applied voltage to the induction motor?

The applied voltage to the induction motor has two components at low frequencies. They are

- a. Proportional to stator frequency.
- b. To compensate for the resistance drop in the stator.

The second component deepens on the load on the motor and hence on rotor frequency.

36. What is indirect flux control?

The method of maintaining the flux constant by providing a voltage boost proportional to slip frequency is a kind of indirect flux control. This method of flux control is not desirable if very good dynamic behaviour is required.

37. What is voltage source inverter?

Voltage source inverter is a kind of D.C. link converter, which is a two stage conversion device.

38. What is the purpose of inductance and capacitance in the D.C. link circuit?

The inductance in the D.C. link circuit provides smoothing whereas the capacitance maintains the constancy of link voltage. The link voltage is a controlled quantity.

39. What are the disadvantages of square wave inverter in induction motor drive?

Square wave inverters have commutation problems at very low frequencies, as the D.C. link voltage available at these frequencies cannot charge the commutating capacitors sufficiently enough to commutate the thyristors. This puts a limit on the lower frequency of operation. To extend the frequency towards zero, special charging circuits must be used.

40. What is slip controlled drive?

When the slip is used as a controlled quantity to maintain the flux constant in the motor the drive is called slip controlled drive. By making the slip negative (i.e., decreasing the output frequency of the inverter). The machine may be made to operate as a generator and the energy of the rotating parts fed back to the mains by an additional line side converter or dissipated in a resistance for dynamic braking. By keeping the slip frequency constant, braking at constant torque and current can be achieved. Thus braking is also fast.

41. What are the effects of harmonics in VSI fed induction motor drive?

The motor receives square wave voltages. These voltages have harmonic components. The harmonics of the stator current cause additional losses and heating. These harmonics are also responsible for torque pulsations. The reaction of the fifth and seventh harmonics with the fundamental gives rise to the seventh harmonic pulsations in the torque developed. For a given induction motor fed from a square wave inverter the harmonic content in the current tends to remain constant independent of input frequency, within the range of operating frequencies of the inverter.

42. What is a current source inverter?

In a dc link converter, if the D.C. link current is controlled, the inverter is called a current source inverter. The current in the D.C. link is kept constant by a high inductance and the capacitance of the filter is dispensed with. A current source inverter is suitable for loads which present low impedance to harmonic currents and have unity p.f.

43. Explain about the commutation of the current source inverter.

The commutation of the inverter is load dependent. The load parameters form a part of the commutation circuit. A matching is therefore required between the inverter and the motor. Multimotor operation is not possible. The inverter must necessarily be a force commutated one as the induction motor cannot provide the reactive power for the inverter. The motor voltage is almost sinusoidal with superimposed spikes.

44. Give the features from which a slip controlled drive is developed.

The stator current of an induction motor operating on a variable frequency, variable voltage supply is independent of stator frequency if the air gap flux is maintained constant. However, it is a function of the rotor frequency. The torque developed is also a function of rotor frequency. The torque developed is also a function of rotor frequency only. Using these features a slip controlled drive can be developed employing a current source inverter to feed an induction motor.

45. How is the braking action produced in plugging?

In plugging, the braking torque is produced by interchange any two supply terminals, so that the direction of rotation of the rotating magnetic field is reversed with respect to the rotation of the motor. The electromagnetic torque developed provides the braking action and brings the rotor to a quick stop.

46. Where is rotor resistance control used?

Where the motors drive loads with intermittent type duty, such as cranes, ore or coal unloaders, skip hoists, mine hoists, lifts, etc. slip-ring induction motors with speed control by variation of resistance in the rotor circuit are frequently used. This method of speed control is employed for a motor generator set with a flywheel (Ilgner set) used as an automatic slip regulator under shock loading conditions.

47. What are the advantages and disadvantages of rotor resistance control?

Advantage of rotor resistance control is that motor torque capability remains unaltered even at low speeds. Only other method which has this advantage is variable frequency control. However, cost of rotor resistance control is very low compared to variable frequency control. Major disadvantage is low efficiency due to additional losses in resistors connected in the rotor circuit.

48. How is the resistance in the output terminals of a chopper varied in rotor resistance control?

The resistance connected across the output terminals of a chopper can be varied from 0 to R by varying the time ratio of the chopper. When the chopper is always OFF, the supply is always connected to the resistance R. The time ratio in this case is zero and the effective resistance connected is R. Similarly when the chopper is always ON, the resistance is short circuited. The time ratio in the case is unity and the effective resistance connected is 0. Hence by varying the time ratio from 0 to 1, the value of resistance can be varied from R to 0.

49. What is the function of inductance L and resistance R in the rotor resistance control circuit?

A smoothing inductance L is used in the circuit to maintain the current at a constant value. Any short circuit in the chopper does not become effective due to L. The value of R connected across the chopper is effective for all phases and its value can be related to the

resistance to be connected in each phase if the conventional method has been used. The speed control range is limited by the resistance.

50. What are the disadvantages and advantages of chopper controlled resistance in the rotor resistance control circuit method?

The method is very inefficient because of losses in the resistance. It is suitable for intermittent loads such as elevators. At low speeds, in particular the motor has very poor efficiency. The rotor current is non-sinusoidal. The harmonics of the rotor current produce torque pulsations. These have a frequency which is six times the slip frequency. Because of the increased rotor resistance, the power factor is better.

51. How is the range of speed control increased for a 3 phase induction motor while employing stator side control?

The range of speed control can be increased if a combination of stator voltage control and rotor resistance control is employed. Instead of using a high resistance rotor, a slip ring rotor with external rotor resistance can be used when stator voltage control is used for controlling the speed.

52. Why the static scherbius drive has a poor power factor?

Drive input power is difference between motor input power and the power fed back. Reactive input power is the sum of motor and inverter reactive power. Therefore, drive has a poor power factor throughout the range of its options.

53. How is super synchronous speed achieved?

Super synchronous speed can be achieved if the power is fed to the rotor from A.C. mains. This can be made possible by replacing the converter cascade by a cycloconverter. A cycloconverter allows power flow in either direction making the static scherbets drive operate at both sub and super synchronous speeds.

54. Give the features of static scherbius drive

The torque pulsations and other reactions are minimal. The performance of the drive improves with respect to additional losses and torque pulsations. A smooth transition is possible from sub to super synchronous speeds without any commutation problems. Speed reversal is not possible. A step up transformer may be interposed between the lines and the converter, to reduce the voltage rating of the converter.

55. Where is Kramer electrical drive system used?

Some continuous rolling mills, large air blowers, mine ventilators, centrifugal pumps and any other mechanisms including pumps drives of hydraulic dredgers require speed adjustment in the range from 15 to 30% below or above normal. If the induction motor is of comparatively big size (100 to 200 KW) it becomes uneconomical to adjust speed by means of external resistances due to copper losses as slip power is wasted as heat in the retort circuit resistance. In this case, the Kramer electrical drive system is used, where slip power recovery takes places.

56. How is the speed control obtained in static Kramer drive?

For speed control below synchronous speed, the slip power is pumped back to the supply, whereas for the case of speed above synchronous speed, additional slip power is injected into the rotor circuit.

57. What is static Kramer drive?

Instead of wasting the slip power in the rotor circuit resistance, it can be converted to 50 Hz A.C. and pumped back to the line. The slip power controlled drive that permits only a sub synchronous range of speed control through a converter cascade is known as static Kramer drive.

58. What is the use and functions of step down transformer in static Kramer drive?

For a restricted speed range closer to synchronous speed, the system power factor can be further improved by using a step-down transformer. The step-down transformer has essentially two functions: besides improving the line power factor, it also helps to reduce the converter power ratings.

59. What are the advantages of static Kramer drive?

The static Kramer drive has been very popular in large power pump and fan-type drives, where the range of speed control is limited near, but below the synchronous speed. The drive system is very efficient and the converted power rating is low because it has to handle only the slip power. In fact, the power rating becomes lower with a more restricted range of speed control. The additional advantages are that the drive system has D.C. machine like characteristics and the control is very simple.

60. What are the causes of harmonic currents in static Kramer drive?

The rectification of slip power causes harmonic currents in the rotor, and these harmonics are reflected to the stator by the transformer action of the machine. The harmonic currents are also injected into the A.C. line by the inverter. As a result, the machine losses are increased and some amount of harmonic torque is produced. Each harmonic current in the rotor will create a rotating magnetic field and its direction of rotation will depend on the order of the harmonic.

61. Give the four modes of operation of a Scherbius drive

The four modes of operation of static Scherbius drive are,

1. Sub synchronous motoring.
2. Sub synchronous regeneration
3. Super synchronous motoring
4. Super synchronous regeneration

62. How is the static Scherbius drive operated in super synchronous motoring mode?

In super synchronous motoring mode, the shaft speed increases beyond the synchronous speed, the slip becomes negative and the slip power is absorbed by the rotor. The slip power supplements the air gap power for the total mechanical power output. The line therefore supplies slip power in addition to stator input power. At this condition, the phase sequence of slip frequency is reversed so that the slip current – induced rotating magnetic field is opposite to that of the stator.

Unit V

1. Give the use of synchronous motors.

Synchronous motors were mainly used in constant speed applications. The development of semiconductor variable frequency sources, such as inverters and cyclo-converters, has allowed their use in draft fans, main line traction, servo drives, etc.

2. How are the stator and rotor of the synchronous motor supplied?

The stator of the synchronous motor is supplied from a thyristor power converter capable of providing a variable frequency supply. The rotor, depending upon the situation, may be constructed with slip rings, where it conforms to a conventional rotor. It is supplied with D.C. through slip rings. Sometimes rotor may also be free from sliding contacts (slip rings), in which case the rotor is fed from a rectifier rotating with rotor.

3. What is the difference between an induction motor and synchronous motor?

An induction motor operates at lagging power factor and hence the converter supplying the same must invariable is a force commutated one. A synchronous motor, on the other hand, can be operated at any power factor by controlling the field current.

4. List out the commonly used synchronous motors.

Commonly used synchronous motors are,

- a. Wound field synchronous motors.
- b. Permanent magnet synchronous motors
- c. Synchronous reluctance synchronous motors.
- d. Hysteresis motors.

5. Mention the main difference between the wound field and permanent magnet motors.

When a wound filed motor is started as an induction motor, D.C. field is kept off. In case of a permanent magnet motor, the field cannot be 'turned off' .

6. Give the advantages and applications of PMSM.

The advantages of PMSM are,

- a. High efficiency
- b. High power factor
- c. Low sensitivity to supply voltage variations.

The application of PMSM is that it is preferred of industrial applications with large duty cycle such as pumps, fans and compressors.

7. Give the uses of a hysteresis synchronous motor.

Small hysteresis motors are extensively used in tape recorders, office equipment and fans. Because of the low starting current, it finds application in high inertia application such as gyrocompasses and small centrifuges.

8. Mention the two modes employed in variable frequency control

Variable frequency control may employ and of the two modes.

- a. True synchronous mode
- b. Self-controlled mode

9. Which synchronous machine is said to be self controlled?

A machine is said to be self controlled if it gets its variable frequency from an inverter whose thrusters are freed in a sequence, using the information of rotor position or stator voltages. In the former a rotor position sensor is employed which measures the rotor position with respect to the stator and sends pulses to the thyristors. Thus frequency of the inverter output is decided by the rotor speed.

10. What is Commutator Less Motor (CLM)?

The self controlled motor has properties of a D.C. Motors both under steady state and dynamic conditions and therefore is called commutator less motor(CLM). These machines have better stability behaviors. They do not fall out of step and do not have oscillatory behaviors, as in normal synchronous motors.

11. Give the application of self controlled synchronous motor.

A self controlled synchronous motor is a substitute for a D.C. motor drive and finds application where a D.C. motor is objectionable due to its mechanical commutator, which limits the speed range and power output.

12. Define load commutation

Commutation of thyristors by induced voltages of load is known as load commutation.

13. List out the advantages of load commutation over forced commutation.

Load commutation has a number of advantages over forced commutation

- It does not require commutation circuits
- Frequency of operation can be higher
- It can operate at power levels beyond the capability of forced commutation.

14. Give some application of load commutated inverter fed synchronous motor drive.

Some prominent applications of load commutated inverter fed synchronous motor drive are high speed and high power drives for compressors, blowers, conveyers, steel rolling mills, main-line traction and aircraft test facilities.

15. How the machine operation is performed in self-controlled mode?

For machine operation in the self-controlled mode, rotating field speed should be the same as rotor speed. This condition is realised by making frequency of voltage induced in the armature. Firing pulses are therefore generated either by comparison of motor terminal voltages or by rotor position sensors.

16. What is meant by margin angle of commutation?

The difference between the lead angle of firing and the overlap angle is called the margin angle of commutation. If this angle of the thyristor, commutation failure occurs. Safe commutation is assured if this angle has a minimum value equal to the turn off angle of the thyristor.

17. What are the disadvantages of VSI fed synchronous motor drive?

VSI synchronous motor drives might impose fewer problems both on machine as well as on the system design. A normal VSI with 180° conduction of thyristors required forced commutation and load commutation is not possible.

18. How is PWM inverter supplied in VSI fed synchronous motor?

When a PWM inverter is used, two cases may arise the inverter may be fed from a constant D.C. source in which case regeneration is straight forward. The D.C. supply to the inverter may be obtained from a diode rectifier. In this case an additional phase controlled converter is required on the line side.

19. What is D.C. link converter and cycloconverter?

D.C. link converter is a two stage conversion device which provides a variable voltage, variable frequency supply. Cycloconverter is a single stage conversion device which provides a Variable voltage, variable frequency supply.

20. What are the disadvantages of cycloconverter?

A cycloconverter requires large number of thyristors and its control circuitry is complex. Converter grade thyristors are sufficient but the cost of the converter is high.

21. What are the applications of cycloconverter?

A cycloconverter drive is attractive for low speed operation and is frequently employed in large, low speed reversing mills requiring rapid acceleration and deceleration. Typical applications are large gearless drives, e.g. drives for reversing mills, mine hoists, etc.

22. Give the application of CSI fed synchronous motor.

Application of this type of drive is in gas turbine starting pumped hydro turbine starting, pump and blower drives, etc.

23. What are the disadvantages of machine commutation?

The disadvantages of machine commutation are,

- a. Limitation on the speed range.
- b. The machine size is large
- c. Due to overexciting it is underutilized.

24. What is the use of an auxiliary motor?

Sometimes when the power is small an auxiliary motor can be used to run up the synchronous motor to the desired speed.

25. What are the advantages of brushless D.C. motor?

The brushless D.C. motor is in fact an inverter-fed self controlled permanent synchronous motor drive. The advantages of brushless D.C. motor are low cost, simplicity, reliability and good performance.

BIG QUESTIONS AND ANSWER KEY

Solid State Drives

1. Give a brief explanation on the selection of drives.[8M]

Ans: 1.Selection of Electric Motors

2.Kinds of Motors

3.Kinds of enclosures

Refer: 'Solid state drives' by V.Thiyagarajan pg.no. 2.41

'Fundamentals of Electric drives' by G.K Dubey pg.no.51

2. Give a brief explanation on the rating of drives.[8M]

Ans: 1.Requirement of a drive motor

2. Power losses & heating of motors
3. Heating & cooling of a Electric motor
Refer: 'Solid state drives' by V.Thiyagarajan pg.no. 2.37
'Fundamentals of Electric drives' by G.K Dubey pg.no.51

3. Explain the four quadrant operation of electric drives.[8M]

Ans: First Quadrant-Forward Motoring
Second Quadrant-Forward Braking
Third Quadrant-Reverse Motoring
Fourth Quadrant- Reverse Braking
T-Wm characteristics
Refer: 'Solid state drives' by V.Thiyagarajan pg.no. 2.33
'Fundamentals of Electric drives' by G.K Dubey pg.no.14

4. Explain the constant torque and constant HP operations.

Ans:
· V/f operation,
· constant torque and constant power operation
· V,T,Pm,Is, Wsl with respect to 'a' per unit frequency
Refer: 'Power semiconductor controlled drives' by G.K Dubey pg.no.233

5. Describe the operation of 1f fully controlled rectifier control of DC separately excited motor and obtain the expression of motor speed for continuous and discontinuous modes of operations.

Ans: Circuit diagram of 1f fully controlled rectifier
Mode of operation under Motoring – Continuous conduction mode
Discontinuous conduction mode
Mode of operation under braking – Continuous conduction mode
Discontinuous conduction mode
Refer: 'Power semiconductor controlled drives' by G.K Dubey pg.no.72

6. Explain the motoring operation and braking operation of three phase fully controlled rectifier control of dc separately excited motor with aid of diagrams and waveforms. Also obtain the expression for motor terminal voltage and speed.

Ans: Circuit diagram of 3f fully controlled rectifier
Mode of operation under Motoring – Continuous conduction mode
Discontinuous conduction mode
Mode of operation under braking – Continuous conduction mode
Discontinuous conduction mode
Refer: 'Power semiconductor controlled drives' by G.K Dubey pg.no.103

7. Explain the operation of chopper for forward motoring and braking control of separately excited dc motor with aid of diagrams, waveforms and speed-torque curves.

Ans: i) Circuit diagram of chopper drive for forward motoring
Waveforms of motor terminal & current – Continuous conduction
Discontinuous conduction
a) Duty interval b) Freewheeling interval equivalent circuits
Refer: 'Power semiconductor controlled drives' by G.K Dubey pg.no.151

ii) Circuit diagram of chopper drive for Regenerative braking of DC motor
Waveforms of motor terminal & current – Continuous conduction
Discontinuous conduction
a) Energy storage interval b) Energy transfer interval equivalent circuits
 $V_a = (1-d)V$
Refer: 'Power semiconductor controlled drives' by G.K Dubey pg.no.159

8. Explain the operation of 1 ϕ half controlled rectifier control of dc separately excited motor for continuous and discontinuous modes of operations with aid of diagrams and waveforms. Also obtain the expression for motor terminal voltage and speed.

Ans: Circuit diagram of 1 ϕ half controlled rectifier
Mode of operation under Motoring – Continuous conduction mode
Discontinuous conduction mode
Refer: 'Power semiconductor controlled drives' by G.K Dubey pg.no.101

9. Explain the operation of chopper controlled dc series motor for motoring and braking with circuit diagrams and waveforms.

Ans: i) Circuit diagram of chopper drive for forward motoring
Waveforms of motor terminal & current – Continuous conduction
Discontinuous conduction
a) Duty interval b) Freewheeling interval equivalent circuits
Refer: 'Power semiconductor controlled drives' by G.K Dubey pg.no.164
ii) Circuit diagram of chopper drive for Regenerative braking of DC motor
Waveforms of motor terminal & current – Continuous conduction
Discontinuous conduction
a) Energy storage interval b) Energy transfer interval equivalent circuits
 $V_a = (1-d)V$
 $\omega_m - T$ curves, $\omega_m - P_{rg}$ curves
Refer: 'Power semiconductor controlled drives' by G.K Dubey pg.no.164

10. Explain the closed loop speed control of DC drives.

Ans: Block diagram, operation – i) drive with current limit control
ii) drive with inner current loop control
Refer: 'Power semiconductor controlled drives' by G.K Dubey pg.no.184

11. Explain the Four Quadrant operation by using Class-E chopper with aid of diagrams and waveforms.

Ans: Circuit diagram & operation – Mode I, II, III, IV
Refer: 'Power semiconductor controlled drives' by G.K Dubey pg.no.175

12. Explain the two Quadrant operation by using Class-D and Class-C chopper with aid of diagrams and waveforms.

Ans: Class-C Circuit diagram & operation – Mode I, II
Class-D Circuit diagram & operation – Mode I, IV
Refer: 'Power semiconductor controlled drives' by G.K Dubey pg.no.169, 172

13. A 200 V, 875 rpm, 150 A separately excited motor has an armature resistance of 0.06 Ω . It is fed from a 1 phase fully controlled rectifier with an ac source voltage of 220 V, 50 Hz. Assuming continuous conduction, Calculate

i) firing angle for rated motor torque and 750 rpm

ii) firing angle for rated motor torque and (-500)rpm.

iii) Motor speed for $\alpha = 1600$ rpm and rated torque.

Solution: E at rated operation $E = V - I_a R_a = 191$ v

i) $\alpha = 29.30$

ii) $\alpha = 1200$

iii) $N = -893.2$ rpm

Refer: 'Fundamentals of Electric drives' by G.K Dubey pg.no.117

14. A 230 V, 960 rpm and 200 A separately excited dc motor has an armature resistance of 0.02W. The motor is fed from a chopper which provides both motoring and braking operations. The source has a voltage of 230 V. Assuming continuous conduction, Calculate

i) duty cycle ratio of chopper for motoring operations at 350 rpm.

ii) duty cycle ratio of chopper for braking operation at rated torque and 350 rpm.

iii) If maximum duty ratio of chopper is limited to 0.95 and maximum permissible motor current is twice the rated. Calculate the maximum permissible motor speed and power fed to the source.

Solution: E at rated operation $E = V - I_a R_a = 226$ v

i) $V_a = E + I_a R_a$, $d = V_a / V$; $d = 0.376$

ii) $V_a = E - I_a R_a$, $1 - d = V_a / V$; $d = 0.66$

iii) $N = 962$ rpm, power = $V_a I_a = 87.4$ KW

Refer: 'Fundamentals of Electric drives' by G.K Dubey pg.no.139

15. A 220 V, 1500 rpm 50 A separately excited motor with armature resistance of 0.5W, is fed from a 3phase fully controlled rectifier. Available ac source has a line voltage of 440 V, 50 Hz. A star-delta connected transformer is used to feed the armature so that motor terminal voltage equals rated voltage when converter firing angle is zero.

a. Calculate the transformer turns ratio.

b. Determine the value of firing angle when

a) motor is running at 1200 rpm & rated torque

b) When motor is running at (-800) rpm & twice the rated torque.

Assume continuous conduction.

Refer: 'Fundamentals of Electric drives' by G.K Dubey pg.no.129

16. Discuss in brief about the control of an induction motor by stator voltage variation using 3 phase voltage controller.

Ans:

- Ac voltage controllers circuit- star and delta
- Four quadrant ac voltage controllers circuit & operation
- Speed-torque curves
- Closed loop speed control

Refer: 'Power semiconductor controlled drives' by G.K Dubey pg.no.274

17. Explain the of operation constant V/f control of induction motor and draw the waveforms.

Ans:

- V/f operation,
- constant torque and constant power operation
- V, T, P_m, I_s, W_{sl} with respect to 'a' per unit frequency

Refer: 'Power semiconductor controlled drives' by G.K Dubey pg.no.233

18. Describe briefly the PWM inverter fed induction motor drive.

Ans: PWM inverter circuits

Control signal generation- sinusoidal PWM Operation

Refer: 'Power semiconductor controlled drives' by G.K Dubey pg.no.298

19. Explain the operation of induction motor fed by current source inverter.

Ans: Current source inverter circuit

CSI variable frequency drives – Block diagram, operation

Refer: 'Power semiconductor controlled drives' by G.K Dubey pg.no.325, 335

20. Starting from the approximate equivalent circuit, derive an expression for the torque-speed characteristics, based on this expression. How does this characteristics change,

i) when stator voltage is varied (keeping frequency constant)

ii) when the rotor resistance is varied?

Ans :

· performance of 3 ϕ IM & equivalent circuits

· speed-torque curves

· expression for torque T

Refer: 'Power semiconductor controlled drives' by G.K Dubey pg.no.206, 226

21. How is dynamic/ regenerative braking achieved in a variable frequency V.S.I/C.S.I fed induction motor drives?

Ans: VSI fed IM drive Block diagram, operation – dynamic braking

- Regenerative braking

CSI fed IM drive Block diagram, operation – dynamic braking

- Regenerative braking

Refer: 'Power semiconductor controlled drives' by G.K Dubey pg.no.316, 336

22. In a pump drive, the fluid flow is to be varied from full down to 50 percent. Stator voltage controlled 3 phase induction motor is used for driving the pump. If full load slip of the motor is 0.15. Evaluate i)the maximum motor current to rated motor current ratio. Also derive the expressions used.

Expression for I_{max}/I_{rated}

Refer: 'Power semiconductor controlled drives' by G.K Dubey pg.no.279

23. Discuss the operation of an open-loop variable frequency voltage source inverter fed induction motor drive.

Ans: Block diagram, Operation

Refer: 'Power semiconductor controlled drives' by G.K Dubey pg.no.315

24. A 3 phase , star connected, 50 Hz, 4 pole induction motor has the following parameters in ohms per phase referred to the stator. $R_s = R_r' = 0.034 \Omega$ & $X_s = X_r' = 0.18 \Omega$. The motor is connected by the variable frequency control with a constant (V/f). Determine the following for an operating frequency of 15 Hz. i) The breakdown torque as a ratio of its value at the rated frequency for motoring and braking.ii) The starting torque and rotor current in terms of their values at the rated frequency.

Solution:

i) Motoring $T_{max} (a=0.2) = 0.68$, $T_{max} (a= 1)$

Braking $T_{max} (a=0.2) = 1.46$, $T_{max} (a= 1)$

ii) $T_s (a=0.2) = 2.6$; $I_{rs}' (a=0.2) = 0.72$, $T_s (a=1)$; $I_{rs}' (a= 1)$

Refer: 'Power semiconductor controlled drives' by G.K Dubey pg.no.235

25. Explain the closed loop scheme of i) speed control of poly phase induction motor by rotor resistance control. ii) Compare this scheme of control with the slip power recovery scheme.

Ans: i) Block diagram, operation

ii) Block diagram, operation

Refer: 'Power semiconductor controlled drives' by G.K Dubey pg.no.362, 380

26. Derive an expression for the torque T for the rotor resistance control using the chopper scheme.

Ans:

- Circuit diagram
- Operation, equivalent circuits
- Derivation for torque

Refer: 'Power semiconductor controlled drives' by G.K Dubey pg.no. 356

27. State the merits and demerits of rotor resistance control of wound rotor induction motor. What are its applications. (8M)

Refer: 'Power semiconductor controlled drives' by G.K Dubey pg.no. 356

28. Explain schematic diagram two methods of super synchronous speed control of slip ring induction motor under slip power recovery scheme. What are the advantages and disadvantages of slip power recovery scheme?

. semiconductor controlled drives' by G.K Dubey pg.no. 383

29. With block diagram explain the closed loop operation of slip power recovery scheme of induction motor. Discuss on the power factor and locus diagram of supply current for constant torque operation of slip power recovery scheme.

Ans:

- Closed speed control operation , block diagram
- Power factor and locus diagram

Refer: 'Power semiconductor controlled drives' by G.K Dubey pg.no. 380, 368

30. Explain with schematic diagram of sub-synchronous speed control of slip-ring induction Motor under slip power recovery scheme. Derive the expression for the torque. (16)

Ans:

- Sub synchronous speed control operation
- static Scherbius drive – diagram, operation
- Expression for torque

Refer: 'Power semiconductor controlled drives' by G.K Dubey pg.no. 366

31. A 3phase, 400 V, 50 Hz, 960 rpm, 6 pole , star connected, wound rotor induction motor has the following parameters per phase referred to the stator. $R_s = 0.3\Omega$, $R_r' = 0.5\Omega$, $X_1 = X_2 = 1.6\Omega$, $X_m = 35\Omega$. Stator to rotor turns ratio is 2. The motor speed is controlled by the static rotor resistance. The filter resistance is 0.01Ω . The value of the external resistance is

chosen such that $a=0$, the break-down torque is obtained at standstill. Determine the value of external resistance.

Solution: $R=1.37 \text{ W}$

Refer: 'Power semiconductor controlled drives' by G.K Dubey pg.no. 365

32. A 440 V, 50 Hz, 960rpm, star- connected wound rotor Induction Motor has: $R_s=0.15\text{W}$, $X_r'=0.6\text{W}$ and $X_m=20\text{W}$. The stator to rotor turns ratio is 2. This motor is controlled by a rotor-chopper scheme. The filter inductor has a resistance of 0.01W. The external resistance is 4W. For a duty cycle of 0.7 and a speed of 600 rpm, evaluate the torque developed.

Solution: $T= 258.98 \text{ Nm}$

Refer: 'Power semiconductor controlled drives' by G.K Dubey pg.no. 365

33. Explain the operation of a 'torque- angle control' based self –controlled synchronous motor drive.

Ans: Block diagram Operation

Refer: 'Power semiconductor controlled drives' by Murphy and Turnbull

34. Write short notes on Brushless Excitation system. (8M)

Ans: diagram (4M)

Operation (4M)

Refer: 'Power semiconductor controlled drives' by G.K Dubey pg.no. 407

35. Explain the working of a self controlled synchronous mode fed from a three phase inverter. Why a self controlled synchronous motor is free from hunting oscillations?

Ans: Rotor position encoder operation -diagram

Brushless AC & DC motor –diagram, Operation

Refer: 'Power semiconductor controlled drives' by G.K Dubey pg.no. 418, 423

36. i) Describe the self control of synchronous motor fed from VSI. Discuss about separately controlled synchronous motor fed from VSI. ii) Compare the above two schemes.

Ans: Self controlled mode - diagram, Operation

True

synchronous mode - diagram, Operation

Refer: 'Power semiconductor controlled drives' by G.K Dubey pg.no. 423, 412

37. Explain the closed loop control scheme of adjustable speed synchronous motor drive.

Ans: VSI and CSI fed Synchronous motor drives

Block diagram (8M)

Operation (8M)

Refer: 'Power semiconductor controlled drives' by G.K Dubey pg.no. 421

38. Explain the operation of a 'power factor control' based self –controlled synchronous motor drive.

Ans: Block diagram

Operation

Refer: 'Power semiconductor controlled drives' by Murphy and Turnbull